



Province of the  
**EASTERN CAPE**  
EDUCATION

**NATIONAL  
SENIOR CERTIFICATE**

**GRADE 11**

**NOVEMBER 2020**

**CIVIL TECHNOLOGY: CONSTRUCTION  
(EXEMPLAR)**

**MARKS: 200**

**TIME: 3 hours**



---

This paper consists of 16 pages, including 2 answer sheets.

---

**REQUIREMENTS:**

1. ANSWER BOOK
2. Drawing instruments
3. A non-programmable pocket calculator

**INSTRUCTIONS AND INFORMATION**

1. This question paper consists of SIX questions: THREE questions are generic and THREE questions are subject specific.
2. Answer ALL the questions.
3. Answer each question as a whole. Do NOT separate subsections of questions.
4. Start the answer to EACH question on a NEW page.
5. Do NOT write in the margins of the ANSWER BOOK.
6. You may use sketches to illustrate your answers.
7. Write ALL calculations and answers in the ANSWER BOOK or on the attached ANSWER SHEETS.
8. Use the mark allocation as a guide to the length of your answers.
9. Make drawings and sketches in pencil, fully dimensioned and neatly finished off with descriptive titles and notes to conform to the *SANS/SABS Code of Practice for Building Drawings*.
10. For the purpose of this question paper, the size of a brick should be taken as 220 mm x 110 mm x 75 mm.
11. Use your own discretion where dimensions and/or details have been omitted.
12. Answer QUESTIONS 5.5 and 6.11 on the attached ANSWER SHEETS, using drawing instruments where necessary.
13. Write your NAME on all ANSWER SHEETS and hand them in with your ANSWER BOOK, whether you have answered the question or not.
14. Drawings in the question paper are NOT to scale.

**QUESTION 1: SAFETY AND MATERIALS (GENERIC)**

Start this question on a NEW page.

- 1.1 What type of personal protective clothing is compulsory to wear on a building site at all times? (1)
- 1.2 Why should you remove your tie when you are operating machines with moving parts? (1)
- 1.3 Identify the following statements as TRUE or FALSE.
- 1.3.1 Two operators are allowed to operate a machine at the same time. (1)
- 1.3.2 Petrol engines may be used inside the workshop. (1)
- 1.3.3 Carry tools with sharp points facing downwards. (1)
- 1.3.4 Non-slip footwear is compulsory when you operate machinery. (1)
- 1.4 Answer the following questions with regard to the storing of materials on site.
- 1.4.1 What can materials be placed on if they cannot be stored directly onto the floor? (1)
- 1.4.2 Why should heaps of sand and stone be covered with plastic? (1)
- 1.4.3 Why should there be dividing walls to separate sand and stone? (1)
- 1.5 Calculate the maximum width of the stacked material if the stack is 1 800 mm high. (Show calculations.) (2)
- 1.6 What is the difference between unreinforced concrete and reinforced concrete? (1)
- 1.7 Name ONE purpose of coarse aggregate in a concrete mixture. (1)
- 1.8 What type of material increases the plasticity of mortar mixtures? (1)
- 1.9 What type of material is used as a levelling layer on concrete floors? (1)
- 1.10 Name the TWO main groups into which wood can be divided. (2 x 1) (2)
- 1.11 Name ONE use of plywood. (1)

- 1.12 Identify the following metals as FERROUS or NON-FERROUS:
- 1.12.1 Copper (1)
- 1.12.2 Cast iron (1)
- 1.13 Name ONE use of lead in the building environment. (1)
- 1.14 Name ONE use of stainless steel in the building environment. (1)
- 1.15 Describe in steps how PVC adhesives must be used. (3 x 1) (3)
- 1.16 What is the minimum thickness of a windowpane? (1)
- 1.17 Name TWO uses of translucent glass. (2 x 1) (2)
- 1.18 Name the TWO main groups into which plastic can be divided. (2 x 1) (2)

**[30]**

**QUESTION 2: EQUIPMENT, TOOLS AND GRAPHICS (GENERIC)**

Start this question on a NEW page.

- 2.1 Why must a spade be oiled lightly when it is not used? (1)
- 2.2 Briefly explain the difference in the uses of the cold chisel and bolster. (2)
- 2.3 Name the tools in FIGURES 2.3.1 to 2.3.3 and name ONE use of each. (6)



**FIGURE 2.3.1**



**FIGURE 2.3.2**

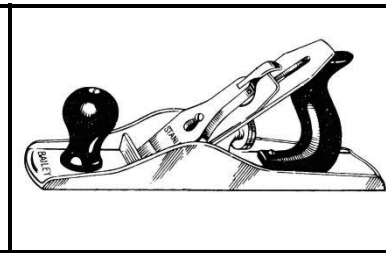

**FIGURE 2.3.3**

(3 x 2) (6)

- 2.4 Answer the following questions with regard to the tool in FIGURE 2.4.



**FIGURE 2.4**

- 2.4.1 What is this tool called? (1)
  - 2.4.2 Briefly explain how this tool will be used during the installation of a doorframe. (2)
  - 2.4.3 Name TWO caring measures of this tool. (2 x 1) (2)
- 2.5 Answer the following questions with regard to the tool in FIGURE 2.5.

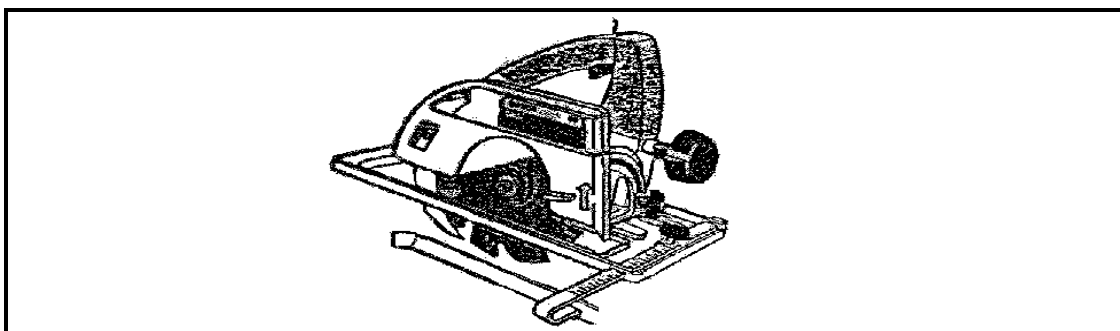

**FIGURE 2.5**

- 2.5.1 What is this tool called? (1)
- 2.5.2 Name TWO uses of this tool. (2 x 1) (2)

- 2.6 Answer the following questions with regard to the detail drawing in FIGURE 2.6.

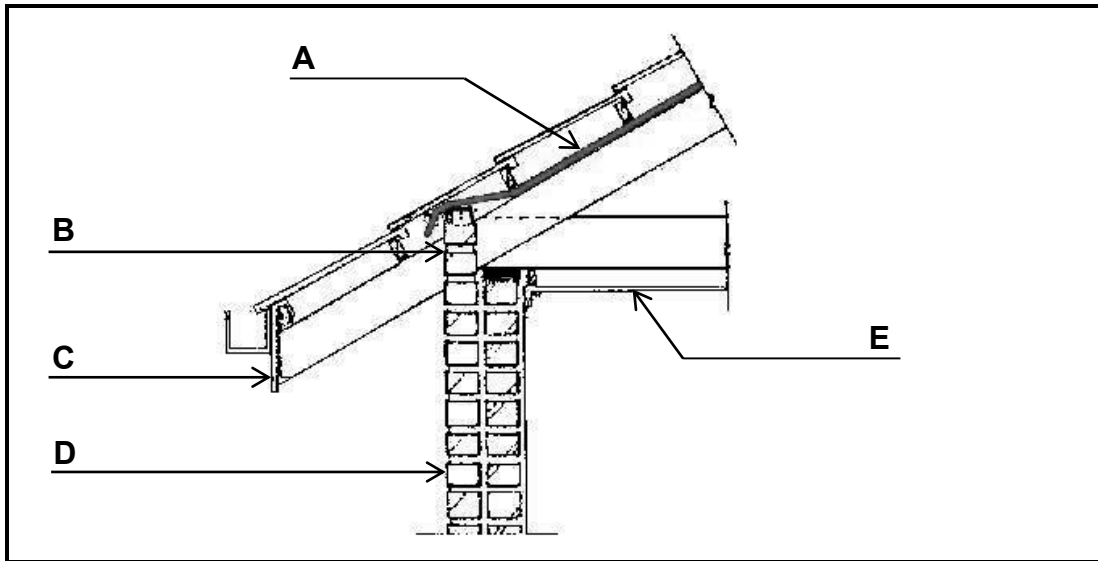

FIGURE 2.6

- 2.6.1 Why are detail drawings drawn on an enlarged scale? (1)
- 2.6.2 Briefly motivate why descriptive notes are included on detail drawings. (2)
- 2.6.3 Which type of eave construction is illustrated in FIGURE 2.6? (1)
- 2.6.4 Name parts **A** to **E**. (5)
- 2.6.5 What is the purpose of part **B**? (1)
- 2.6.6 What is the purpose of part **C**? (1)
- 2.7 Explain the purpose of the control test for floor plan dimensions. (2)
- 2.8 Explain the position, on the drawing sheet for building plans, where the north arrow must be indicated. (2)
- 2.9 On which scale are floor plans usually drawn? (1)
- 2.10 Identify the following abbreviations on elevations of buildings:
- 2.10.1 NGL (1)
- 2.10.2 FFL (1)
- 2.11 Make neat sketches to illustrate the following symbols on floor plans:
- 2.11.1 Window (2)
- 2.11.2 Electricity meter (2)
- 2.11.3 Drain (1)

[40]

**QUESTION 3: JOINING AND GRAPHICS (GENERIC)**

Start this question on a NEW page.

3.1 Answer the following questions with regard to the plan elevation in FIGURE 3.1.

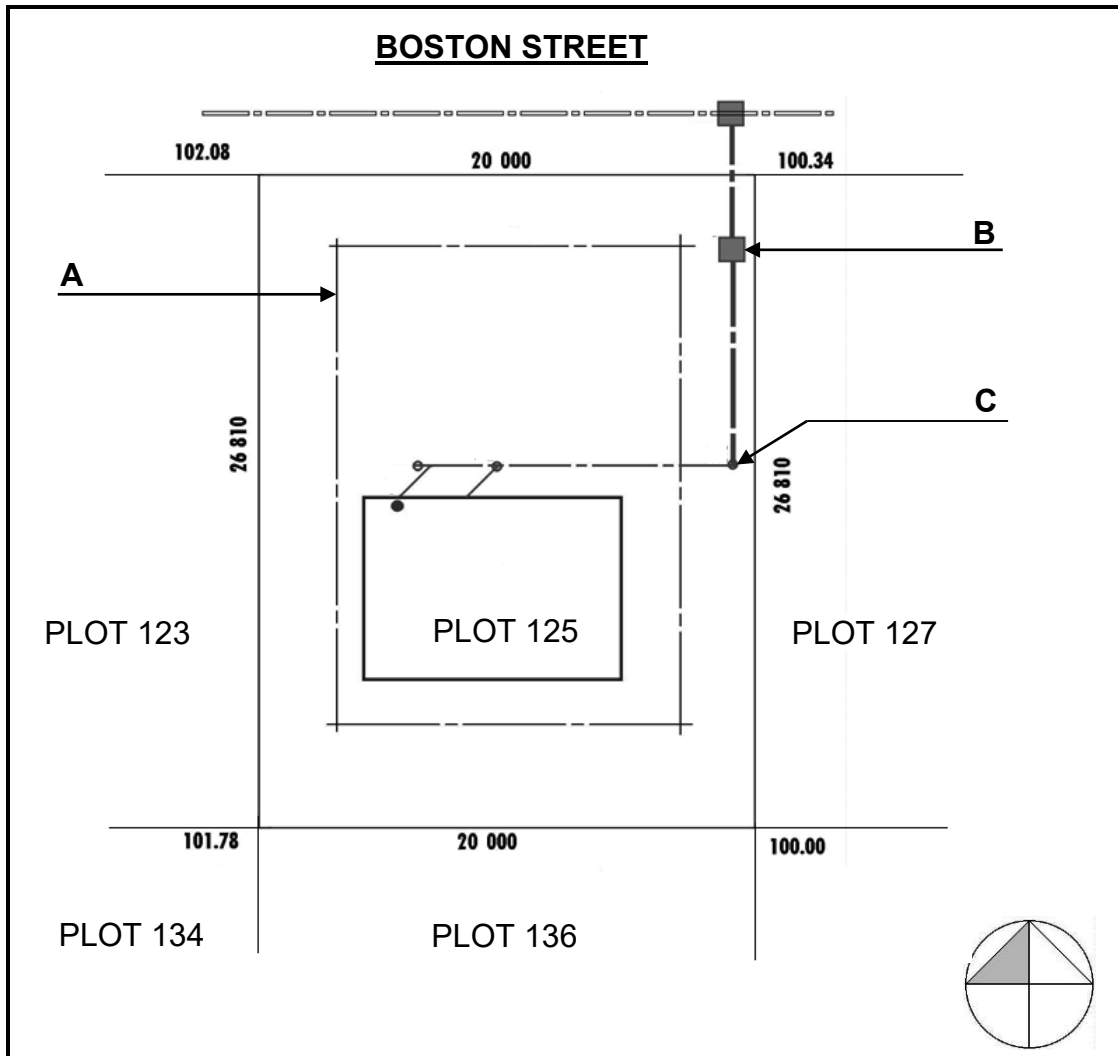

**FIGURE 3.1**

- 3.1.1 What is the plan elevation called? (1)
- 3.1.2 What is the plot number of the plot at the west side of plot 125? (1)
- 3.1.3 What are the lines at **A** called? (1)
- 3.1.4 Identify the symbols at **B** and **C**. (2 x 1) (2)

- 3.2 Name ONE use of PVC glue. (1)
- 3.3 Which adhesive joining material consists of glue? (1)
- 3.4 Make neat sketches to illustrate the following symbols on a floor plan:
- 3.4.1 Gully (2)
- 3.4.2 Earth (2)
- 3.4.3 Dressed wood (2)
- 3.5 Briefly describe the application steps of PVA adhesive. (3 x 1) (3)
- 3.6 Briefly name THREE precautions when using contact glue. (3 x 1) (3)
- 3.7 Name any FIVE uses of silicone. (5 x 1) (5)
- 3.8 State TWO properties of EACH of the following adhesives:
- 3.8.1 Silicone (2)
- 3.8.2 Contact glue (2)
- 3.8.3 PVA glue (2)

**[30]**



**QUESTION 4: MATERIAL, EQUIPMENT AND JOINING (SPECIFIC)**

Start this question on a NEW page.

4.1 Identify the following statements as TRUE or FALSE.

4.1.1 Face bricks do not require plaster. (1)

4.1.2 Solid concrete bricks cannot be cut by using a trowel. (1)

4.1.3 The cavities in a cellular brick form more than 25% of the brick volume. (1)

4.1.4 The frogs in a keyed brick increase the manufacturing cost. (1)

4.1.5 Hollow concrete blocks are brittle and break easily. (1)

4.1.6 Concrete paving bricks can be laid without mortar. (1)

4.2 What is the length of a queen closer? (1)

4.3 In what type of bond is the queen closer used? (1)

4.4 Name the THREE basic materials for the manufacturing of clay bricks. (3 x 1) (3)

4.5 Choose a description from COLUMN B that best fits the item in COLUMN A. Write only the letter next to the question numbers in the ANSWER BOOK, for example, 4.5.6 H.

COLUMN A	COLUMN B
4.5.1 Durability	A lintels
4.5.2 15 MPa concrete	B resistant to scratching and scouring
4.5.3 Elasticity	C changes form permanently
4.5.4 30 MPa concrete	D floor slabs
4.5.5 Hardness	E resistant to environmental factors
	F can return to its original shape
	G foundations

(5 x 1) (5)

4.6 Answer the following with regard to the construction machine in FIGURE 4.6.



**FIGURE 4.6**

- 4.6.1 What is this machine called? (1)
- 4.6.2 Name ONE use of this machine. (1)
- 4.7 Answer the following questions in regard to scaffolding.
- 4.7.1 What is the purpose/function of the kickboard? (1)
- 4.7.2 What is the purpose/function of the soleplate? (1)
- 4.7.3 What are the horizontal parts of scaffolding called? (1)
- 4.7.4 What type of scaffolding is limited to a height below two metres? (1)
- 4.7.5 What type of scaffolding can easily be moved from one place to another? (1)
- 4.8 Name TWO ways of fixing wooden door and wooden window frames to brickwork. (2 x 1) (2)
- 4.9 Name TWO types of wall ties. (2 x 1) (2)
- 4.10 Answer the following questions with regard to cavity wall construction.
- 4.10.1 What is the purpose/function of weep holes? (1)
- 4.10.2 What is the maximum length of a cavity wall? (1)
- 4.10.3 In what type of climate will ventilating bricks be placed at the bottom of external walls? (1)

**[30]**

**QUESTION 5: EXCAVATIONS, FOUNDATIONS AND STEEL (SPECIFIC)**

Start this question on a NEW page.

5.1 Answer the following questions with regard to the foundation excavation in FIGURE 5.1.

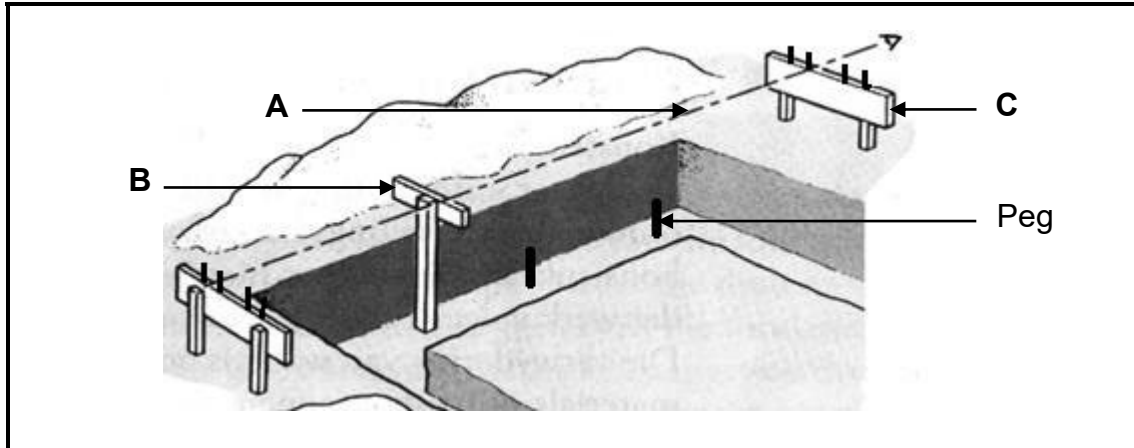

**FIGURE 5.1**

- 5.1.1 Name parts **A** to **C**. (3 x 1) (3)
- 5.1.2 How deep must the pegs be driven into the ground? (1)
- 5.1.3 What is the purpose/function of the pegs? (1)
- 5.1.4 Name TWO types of equipment that can be used to ensure that the pegs are level. (2 x 1) (2)
- 5.2 What is the cheapest method of dewatering trenches? (1)
- 5.3 Identify the following statements as TRUE or FALSE.
- 5.3.1 Topsoil must be cleared to a depth of 300 mm. (1)
- 5.3.2 Timber is the best material for formwork at excavations. (1)
- 5.3.3 Shutter oil makes the removal of formwork boards easier. (1)
- 5.4 Identify and choose THREE of the conditions below that could cause trench accidents.
- 5.4.1 Excavated earth is more than 600 mm from the edge of the trench
- 5.4.2 Excavated earth is less than 600 mm from the edge of the trench
- 5.4.3 Changing ground conditions, especially after rainfalls
- 5.4.4 Ground that was not previously disturbed
- 5.4.5 Near streams, old sewers and underground cables (3 x 1) (3)

- 5.5 ANSWER SHEET A shows an incomplete vertical section of an excavation in firm soil. Complete ANSWER SHEET A by drawing in the necessary formwork parts on the **left-hand** side. (6)
- 5.6 Choose a description from COLUMN B that best fits the item in COLUMN A. Write only the letter next to the question numbers in the ANSWER BOOK, for example 5.6.4 E.

COLUMN A	COLUMN B
5.6.1 Franki-pile	A steel tube caisson stays in the ground
5.6.2 Prefabricated pile	B enlarged concrete base
5.6.3 Short-bored pile	C maximum depth of 15 metres
	D concrete pile with a steel tip

(3 x 1) (3)

- 5.7 Name THREE advantages of piles. (3 x 1) (3)
- 5.8 Choose a steel profile from the list below for each of the following descriptions.

I-beam; H-beam; U-channel; lip channel; angle iron
--

- 5.8.1 Are sometimes referred to as purlins (1)
- 5.8.2 The flanges and web differ in size (1)
- 5.8.3 Metal rail that fits over shower glass panels (1)
- 5.8.4 The flanges and web are the same size (1)

**[30]**

**QUESTION 6: FORMWORK, BRICKWORK, STAIRS AND QUANTITIES (SPECIFIC)**

Start this question on a NEW page.

- 6.1 Describe THREE requirements of good formwork. (3 x 1) (3)
- 6.2 Define the following terms:
  - 6.2.1 In-situ concrete (1)
  - 6.2.2 Formwork (2)
- 6.3 Name TWO reasons for the cover depth of reinforcement in concrete. (2 x 1) (2)
- 6.4 What is the thickness of a lintel used in a one-brick wall? (1)
- 6.5 Name TWO disadvantages of prefabricated lintels. (2 x 1) (2)
- 6.6 Why are the sides of lintels slightly tapered? (1)
- 6.7 Answer the following questions on the wall construction in FIGURE 6.7.

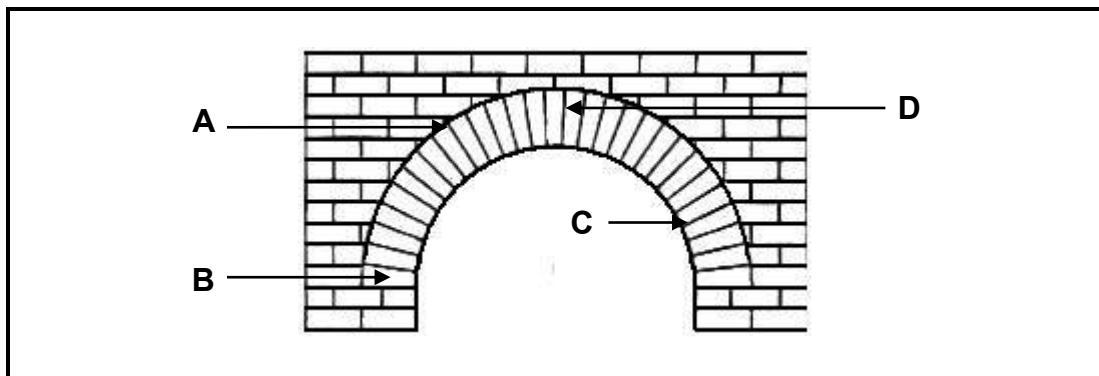

**FIGURE 6.7**

- 6.7.1 Is this a *rough* or a *gauged arch* in the wall construction? (1)
- 6.7.2 Name parts **A** to **D**. (4 x 1) (4)
- 6.8 Name ONE type of material that can be used for the construction of stairs. (1)
- 6.9 Provide ONE word for the following statements of staircases.:
  - 6.9.1 The vertical part of a stair (1)
  - 6.9.2 The horizontal part of a stair (1)
  - 6.9.3 The horizontal distance covered by the flight of stairs (1)
- 6.10 What is the minimum width of a stair? (1)

6.11 FIGURE 6.11 shows a floor plan of a single garage.

Detail:

D1 = 2 400 x 2 100 mm

Wall width = 220 mm and the wall height = 2 700 mm

Outside measurement = 6 000 mm and the inside measurement = 3 000 mm

Calculate on ANSWER SHEET B the amount of bricks required. (18)

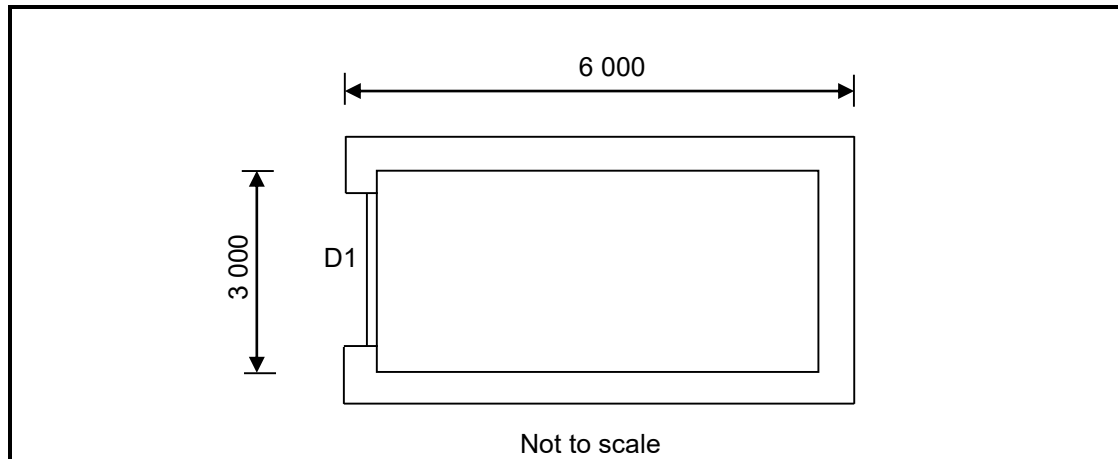

**FIGURE 6.11**

[40]

**TOTAL: 200**

<b>ANSWER SHEET</b>	<b>A</b>	<b>CIVIL TECHNOLOGY CONSTRUCTION</b>	<b>NAME AND SURNAME</b>	

5.5 ANSWER SHEET A shows an incomplete vertical section of an excavation in loose, dry soil. Complete ANSWER SHEET A by drawing in the necessary formwork parts on the **left-hand** side. (6)



Not to scale

<b>ASSESSMENT CRITERIA</b>	<b>MARK</b>	<b>CANDIDATE'S MARK</b>
Vertical plank	1	
Vertical plank - correct depth	1	
Yoke	1	
Wedge	1	
Strut	1	
Parts drawn in good proportion / scale	1	
<b>TOTAL</b>	<b>6</b>	

<b>ANSWER SHEET</b>	<b>B</b>	<b>CIVIL TECHNOLOGY CONSTRUCTION</b>	<b>NAME AND SURNAME</b>	

6.11 Calculate the amount of bricks required.

(18)

<b>A</b>	<b>B</b>	<b>C</b>	<b>D</b>
			<b>Centre line:</b>
			<b>Area of wall:</b>
			<b>Area of door:</b>
			<b>True area of bricks:</b>
			<b>Bricks:</b>