

SA's Leading Past Year

Exam Paper Portal

STUDY

You have Downloaded, yet Another Great Resource to assist you with your Studies 😊

Thank You for Supporting SA Exam Papers

Your Leading Past Year Exam Paper Resource Portal

Visit us @ [www.saexampapers.co.za](http://www.saexampapers.co.za)



SA EXAM  
PAPERS



# basic education

---

Department:  
Basic Education  
**REPUBLIC OF SOUTH AFRICA**

## **SENIOR CERTIFICATE EXAMINATIONS/ NATIONAL SENIOR CERTIFICATE EXAMINATIONS**

**CIVIL TECHNOLOGY: WOODWORKING**

**2022**

**MARKS: 200**

**TIME: 3 hours**



**This question paper consists of 16 pages and 10 answer sheets.**

**REQUIREMENTS:**

1. Drawing instruments
2. A non-programmable calculator
3. ANSWER BOOK

**INSTRUCTIONS AND INFORMATION**

1. This question paper consists of SIX questions.
2. Answer ALL the questions.
3. Read all the questions carefully.
4. Answer each question as a whole. Do NOT separate subsections of questions.
5. Number the answers correctly according to the numbering system used in this question paper.
6. Start the answer to EACH question on a NEW page.
7. Do NOT write in the margins of the ANSWER BOOK.
8. You may use sketches to illustrate your answers.
9. Write ALL calculations and answers in the ANSWER BOOK or on the attached ANSWER SHEETS.
10. Use the mark allocation as a guide to the length of your answers.
11. Make drawings and sketches in pencil, fully dimensioned and neatly finished off with descriptive titles and notes to conform to the *SANS/SABS Code of Practice for Building Drawings*.
12. For the purpose of this question paper, the size of a brick should be taken as 220 mm x 110 mm x 75 mm.
13. Use your own discretion where dimensions and/or details have been omitted.
14. Answer QUESTIONS 2, 3.4, 3.5, 4.5, 4.6, 5.3, 5.4, 6.5, 6.6 and 6.7 on the attached ANSWER SHEETS using drawing instruments where necessary.
15. Write your CENTRE NUMBER and EXAMINATION NUMBER on every ANSWER SHEET and hand them in with your ANSWER BOOK, whether you have used them or not.
16. Drawings in the question paper are NOT to scale due to electronic transfer.
17. Google Images were used as the source of all photographs and pictures.
18. Write neatly and legibly.



**QUESTION 1: OHS&A, MATERIALS, TOOLS, EQUIPMENT AND JOINING (GENERIC)**

Start this question on a NEW page.

1.1 Give ONE word/term for each of the following descriptions. Write only the word/term next to the question numbers (1.1.1 to 1.1.5) in the ANSWER BOOK, e.g. 1.1.6 preservative.

- 1.1.1 Can be melted again because no chemical process is involved (1)
- 1.1.2 The coating of a metal by using the process of electrolysis (1)
- 1.1.3 The process of keeping freshly cast concrete moist/damp for a specific period (1)
- 1.1.4 Available in a matt and gloss finish (1)
- 1.1.5 A process used to coat steel with a layer of zinc (1)

1.2 FIGURE 1.2 below shows a ladder that is used on a construction site.



**FIGURE 1.2**

- 1.2.1 Why should non-skid material be fitted to the bottom end of the stiles of a ladder? (1)
- 1.2.2 Explain why it is better to use a wooden ladder when working near electrical cables. (1)
- 1.2.3 Explain why you would prefer to use an aluminium ladder instead of a wooden ladder. (1)
- 1.2.4 Name TWO methods that can be used to treat wooden ladders. (2)



- 1.3 Describe TWO safety regulations that a scaffold platform must adhere to. (2)
- 1.4 Name TWO places on a building site where safety nets should be erected to ensure the safety of the workers. (2)
- 1.5 FIGURE 1.5 below shows a joining fixture.



**FIGURE 1.5**

- 1.5.1 Identify the joining fixture. (1)
- 1.5.2 Explain the first THREE steps you would follow to attach a bracket to a brick wall by using the fixture above after the position of the hole has been marked. (3)
- 1.6 Complete in your ANSWER BOOK the information in the table below by indicating ONE use and ONE way to care for the tool.

NAME OF TOOL	USE	WAY TO CARE
Dumpy level	To determine ...	Protect the dumpy level by ...

(2)  
[20]

**QUESTION 2: GRAPHICS AS MEANS OF COMMUNICATION (GENERIC)**

FIGURE A and FIGURE B on the next page show drawings that appear on a building plan. Analyse the drawings and complete the table on ANSWER SHEET 2.



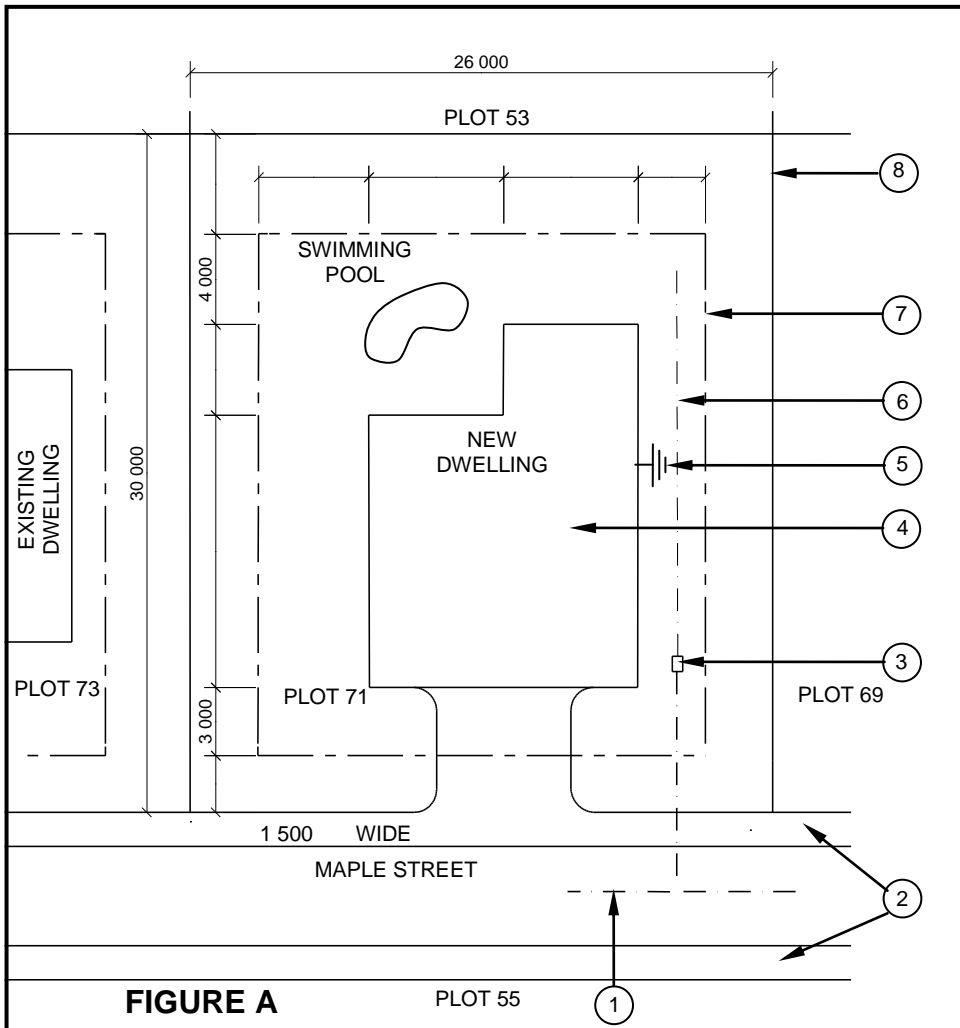

**NOTES:**  
Contractors must verify all dimensions and levels on site before commencing work. Architects must be notified of any discrepancies immediately.

Wall thickness: External = 220 mm  
Internal = 110 mm

Architect's signature .....

Client's signature .....

Precast concrete fencing must be erected on the boundary of the new dwelling.

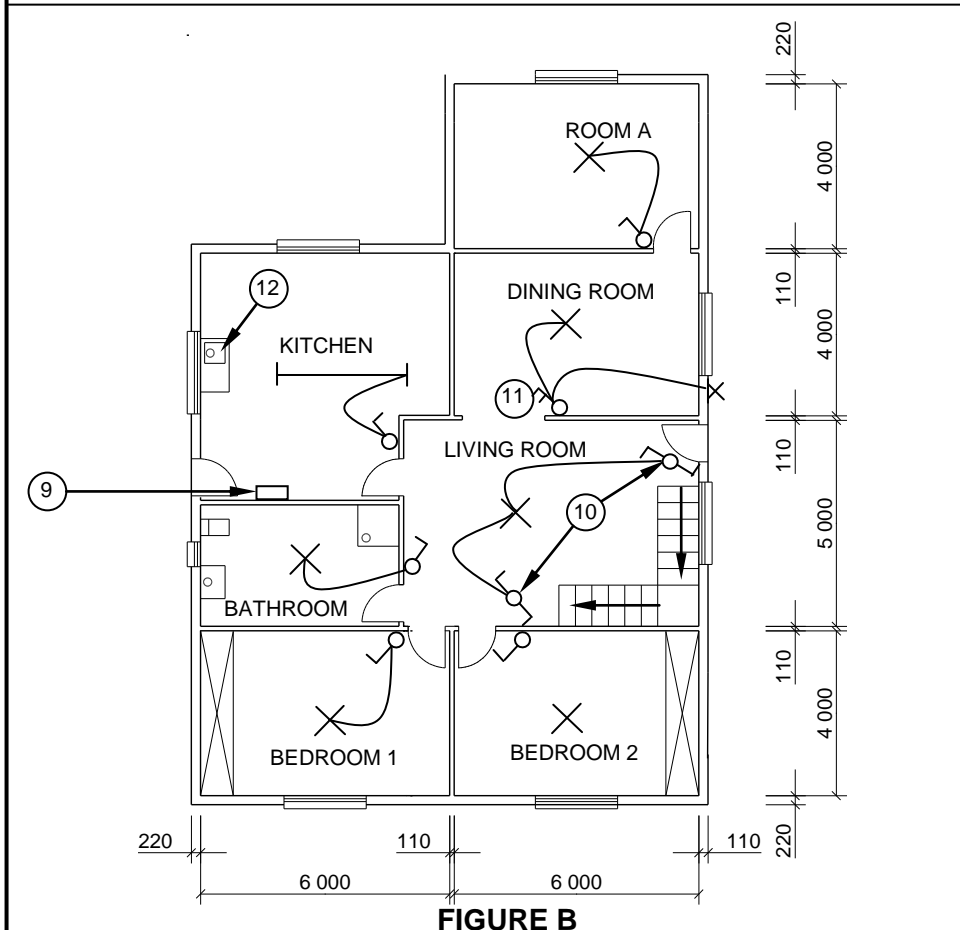

REVISION: 1	DATE: 18/04/2022	DESCRIPTION: WINDOW IN ROOM A
----------------	---------------------	----------------------------------

PRINTED BY: TEXON PRINTERS	DATE OF PRINT: 24/04/2022
-------------------------------	------------------------------

DRAWING TITLE: SITE AND FLOOR PLAN PLOT 71
---

PROJECT: PROPOSED DWELLING ON PLOT 71, JEFFREYS BAY
---

PROJECT NO.: GR 339-670	DRAWING NO.: 443P8
----------------------------	-----------------------

DATE: 12/02/2022	DRAWN: JP COX	CHECKED: C LEE
---------------------	------------------	-------------------

SITE PLAN	SCALE: 1 : 500
-----------	----------------

FLOOR PLAN	SCALE 1 : 100
------------	---------------

REFERENCE CODE QP 4 - 2022
-------------------------------



**QUESTION 3: CUPBOARDS, CASEMENTS, WALL-PANELLING AND QUANTITIES (SPECIFIC)**

Start this question on a NEW page.

- 3.1 Give ONE word/term for each of the following descriptions by choosing a word/term from the list below. Write only the word/term next to the question numbers (3.1.1 to 3.1.5) in the ANSWER BOOK, e.g. 3.1.6 window.

top rail; transom; window pane; mullion; drip groove; casement; fanlight; sill; glazing bars; frame stile; frame head
--

- 3.1.1 The bottom horizontal member of the casement frame, fixed to the wall by means of horns on both ends (1)
- 3.1.2 The middle vertical member between the casement stiles (1)
- 3.1.3 The outer vertical member of the frame (1)
- 3.1.4 The horizontal member that separates the casement and the fanlight (1)
- 3.1.5 The horizontal members between the rails of a casement (1)
- 3.2 Draw, in your ANSWER BOOK, a neat freehand sketch of the sectional view of only the top rail of a casement. (3)



- 3.3 FIGURE 3.3 below shows the front elevation of a built-in cupboard without doors.

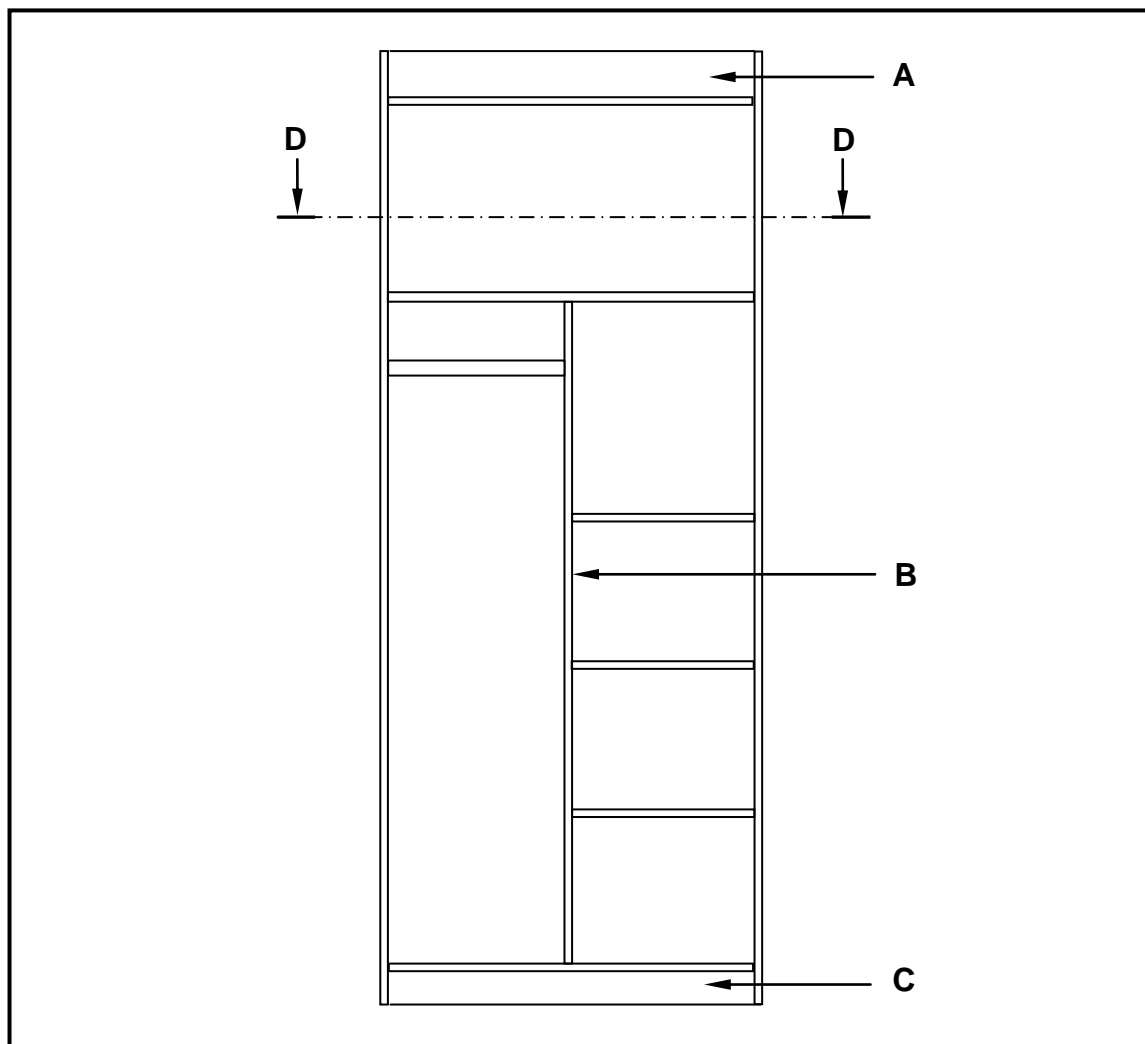

**FIGURE 3.3**

- 3.3.1 Identify parts **A** to **C**. (3)
- 3.3.2 Describe the purpose of a hanging rail in a cupboard. (1)
- 3.3.3 Draw, in your ANSWER BOOK, a neat freehand sketch of section **D-D**. (4)
- 3.4 Use ANSWER SHEET 3.4 and draw, in good proportion, a vertical sectional view of the middle part of a wall panel made of tongue and groove boards. (4)





- 3.5 FIGURE 3.5 below shows a sectional view of a building with a lean-to roof. Study the figure and answer the questions that follow. Give your answers in metres (m).

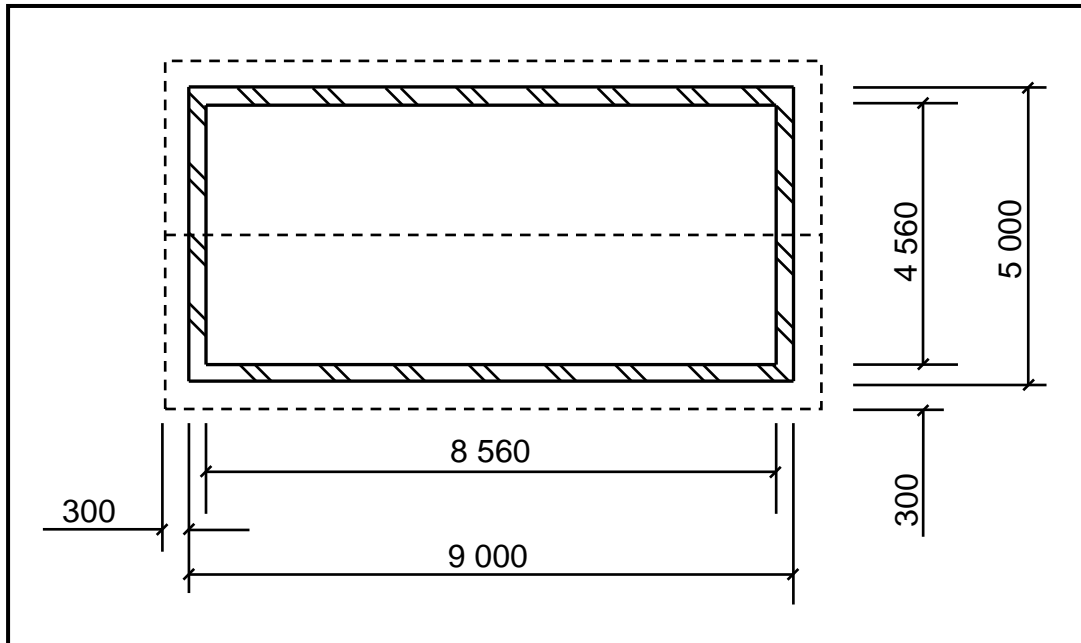

**FIGURE 3.5**

Use the following specification:

- The construction of the lean-to roof consists of EIGHT rafters and FOUR purlins.

Use the dimension sheet on ANSWER SHEET 3.5, ignore the slope of the roof and calculate the following:

- 3.5.1 The total length of the rafters needed if the length of the rafter is 5 600 mm (3)
- 3.5.2 The total length of the purlins needed if the length of the purlin is 9 600 mm (3)
- 3.5.3 The total area of underlay needed if the underlay ends on the outside walls (4)

**[30]**



**QUESTION 4: ROOFS, CEILINGS, TOOLS, EQUIPMENT AND MATERIALS (SPECIFIC)**

Start this question on a NEW page.

- 4.1 Choose a description from COLUMN B that matches an item in COLUMN A. Write only the letter (A–L) next to the question numbers (4.1.1 to 4.1.8) in the ANSWER BOOK, e.g. 4.1.9 M.

COLUMN A		COLUMN B	
4.1.1	Jig saw	A	sanding can be done in any direction
4.1.2	Orbital sander	B	ensure that the cutting tool rests on the tool rest
4.1.3	Morticing machine	C	apply wax to the sole so that the machine glides easily across the work piece
4.1.4	Radial arm saw	D	always lock the tool rest 200 mm from the stock
4.1.5	Spindle moulder	E	always check the tension of the blade before cutting commences
4.1.6	Lathe	F	tension applied to the sanding belt should not exceed its strength
4.1.7	Router	G	avoid shaping pieces of timber shorter than 250 mm
4.1.8	Band saw	H	do not force material onto the chisel or drill bit
		I	do not force material onto the sanding belt
		J	to cut out circles, first drill a hole to insert the blade
		K	avoid making adjustments while the blade is rotating
		L	lock the table at one height for all work to be done

(8 x 1) (8)



- 4.2 Name and describe TWO methods that are used to grade timber. (4)
- 4.3 State ONE preservative that can be used on wood. (1)
- 4.4 FIGURE 4.4 below shows a roof construction.

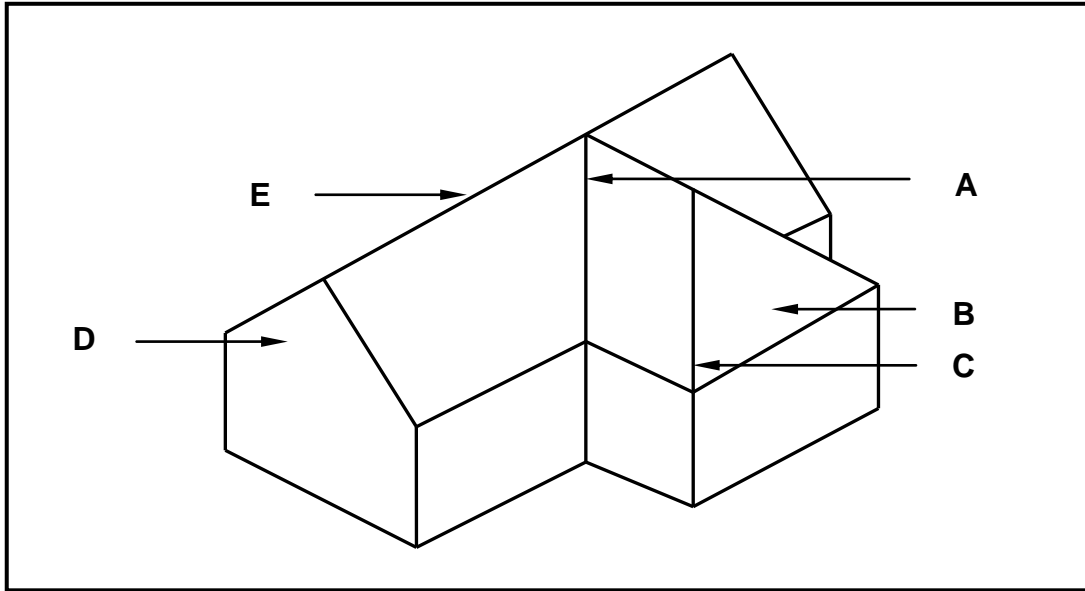

**FIGURE 4.4**

- Identify parts **A** to **E**. (5)
- 4.5 Use ANSWER SHEET 4.5 and draw, in good proportion, a detailed vertical sectional view of the foot of the roof, showing the details of the open eaves, roof covering and rainwater system of a roof. Label any TWO parts with dimensions. (14)
- 4.6 Use ANSWER SHEET 4.6 and draw, in good proportion, the vertical sectional view of the construction of a conventional trapdoor. (8)

**[40]**



**QUESTION 5: CENTERING, FORMWORK, SHORING AND GRAPHICS AS MEANS OF COMMUNICATION (SPECIFIC)**

Start this question on a NEW page.

5.1 FIGURE 5.1 below shows a part of an incomplete shoring.

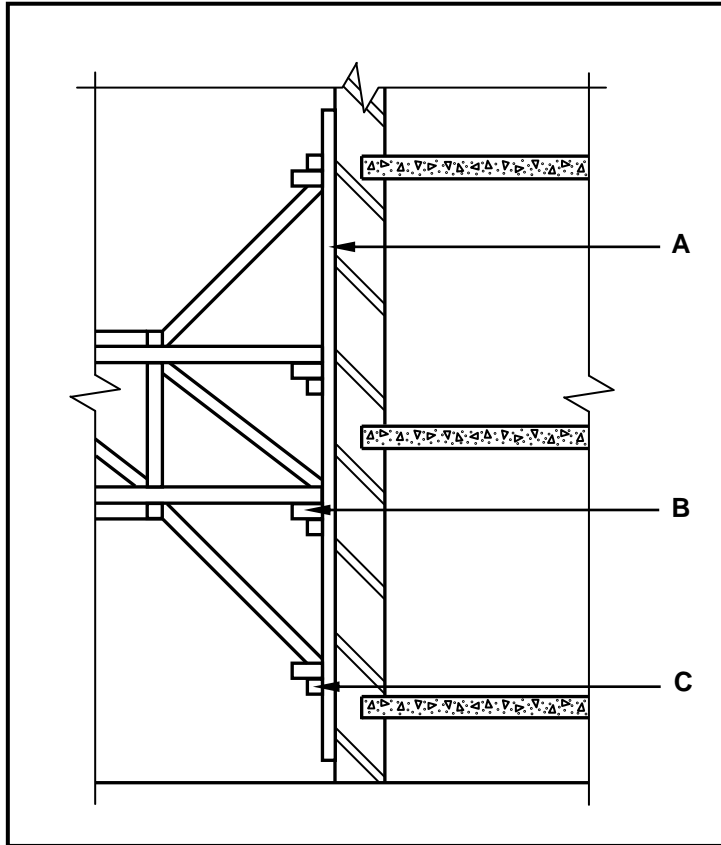

**FIGURE 5.1**

5.1.1 Identify the type of shoring shown in FIGURE 5.1. (1)

5.1.2 Name parts **A** to **C**. (3)



5.2 FIGURE 5.2 below shows the timber laggings used in centering.

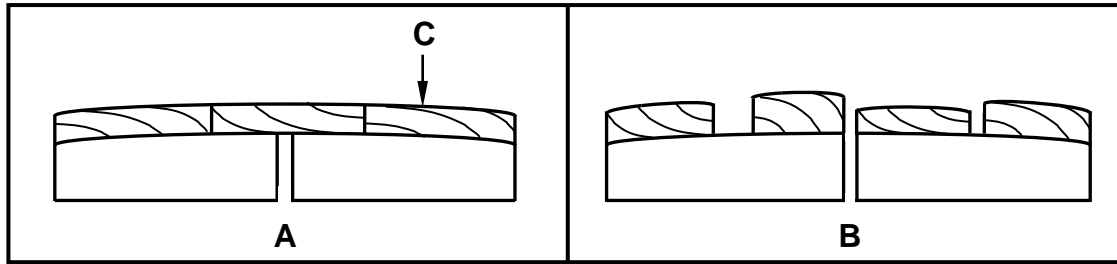

FIGURE 5.2

- 5.2.1 Identify the types of laggings in **A** and **B** respectively. (2)
- 5.2.2 Identify TWO mistakes in the centerings. (2)
- 5.2.3 Describe how you will rectify the mistakes. (2)
- 5.2.4 Name ONE other material that can be used for **C**. (1)

5.3 Use ANSWER SHEET 5.3 and draw, in good proportion, the front view of a lean-to roof truss. The bearing and parapet walls should be shown. Label any TWO members and add dimensions. (8)

5.4 ANSWER SHEET 5.4 shows the incomplete sectional view of the formwork of a concrete beam with an attached floor on both sides.

Use ANSWER SHEET 5.4 and draw the parts below the bearer/head tree to show the completed formwork. Label any TWO of the parts that you have added.

(11)  
[30]



**QUESTION 6: SUSPENDED FLOORS, STAIRCASES, IRONMONGERY, DOORS AND JOINING (SPECIFIC)**

Start this question on a NEW page.

6.1 Various options are given as possible answers to the following questions. Choose the answer and write only the letter (A–D) next to the question numbers (6.1.1 to 6.1.5) in the ANSWER BOOK, e.g. 6.1.6 C.

- 6.1.1 A wall plate can be secured to a wall by means of ...
- A steel nails.
  - B a bolt.
  - C screws.
  - D wire. (1)
- 6.1.2 A ... is used to secure a roof truss to the wall plate.
- A galvanised hoop-iron strap
  - B gang nail
  - C truss hanger
  - D All the above-mentioned (1)
- 6.1.3 Roof tiles are ... to the batten.
- A bolted
  - B tied with wire
  - C strapped with hoop-iron straps
  - D nailed (1)
- 6.1.4 Adjacent members of a roof truss are joined together by means of ...
- A storm clips.
  - B hoop iron (metal strips).
  - C gang nails.
  - D None of the above-mentioned (1)
- 6.1.5 You will use ... to fix brandering to a tie beam.
- A straps
  - B bolts
  - C gang nails
  - D nails (1)



6.2 The various uses or placement of different locks and latches are described below.

Name the lock or latch that:

- 6.2.1 Is mounted onto the internal surface of the door, while the keepers are screwed onto the door jamb (1)
- 6.2.2 Is fitted into a recess on the internal surface of the cupboard door (1)
- 6.2.3 Can be used on its own, but is commonly used with another locking device for extra security (1)
- 6.2.4 Is ideal for front and back doors, internal doors and panel doors (1)

6.3 FIGURE 6.3 below shows two methods of joining floor joists to a wall.

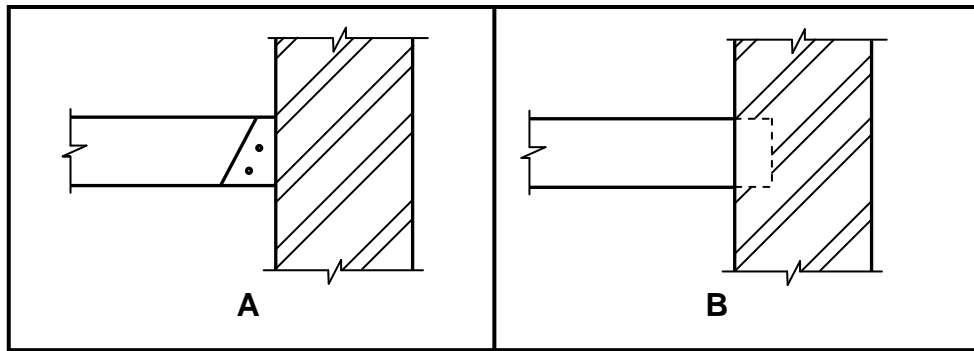
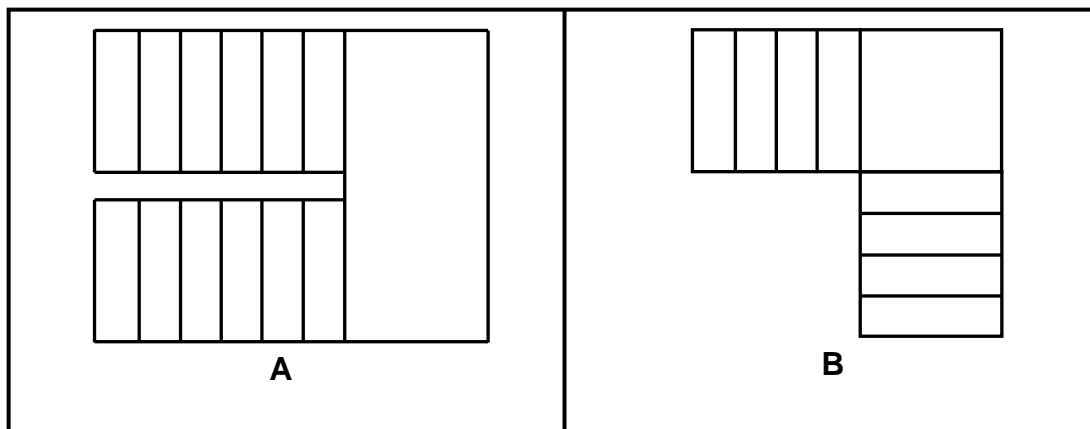

FIGURE 6.3

- 6.3.1 Describe the joining methods used to join the floor joist to the wall in **A** and **B** respectively. (2)
- 6.3.2 Explain why you would prefer method **A**. (2)

6.4 The figures below are different drawings of staircases with landings.



- 6.4.1 Identify the different types of landings in **A** and **B**. (2)
- 6.4.2 Explain TWO reasons for installing a landing. (2)



- 6.5 Use ANSWER SHEET 6.5 and draw, in good proportion, a neat isometric view of part **B** for an open double/twin mortice and tenon joint.

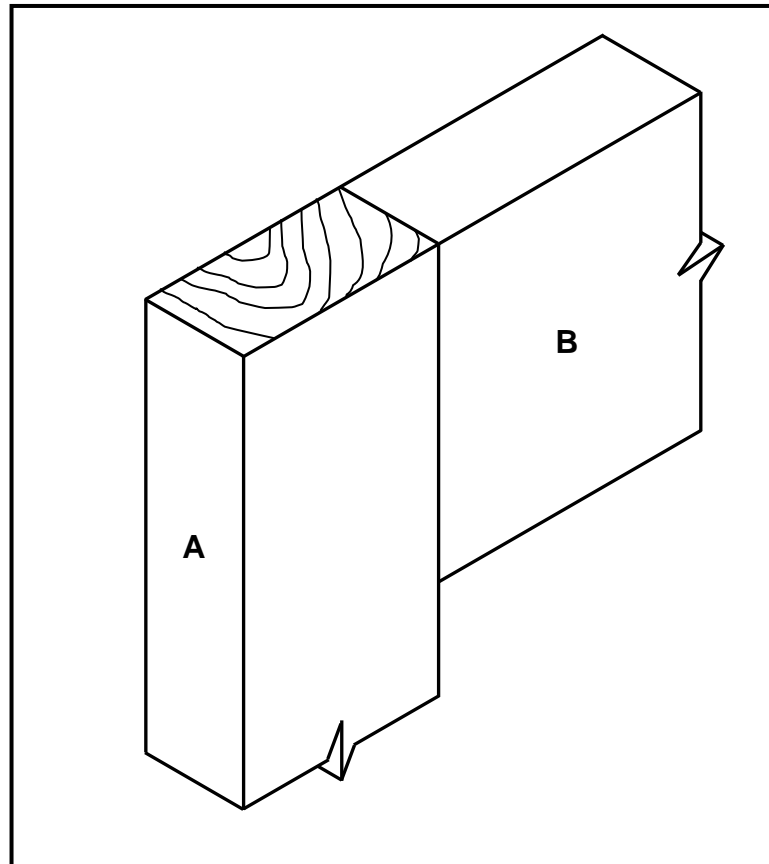

**FIGURE 6.5**

(6)

- 6.6 ANSWER SHEET 6.6 shows an incomplete sectional view of a suspended timber floor with tongue and groove floor boards.

Draw the complete drawing to indicate the following:

- The external wall to accommodate a suspended timber floor
- Plaster on both sides of the wall
- Air brick
- Ant guard
- Damp-proof course (DPC)
- Foundation

(8)





6.7 FIGURE 6.7 below shows the front elevation of an entrance door with a glass panel on top and a raised and fielded panel at the bottom.

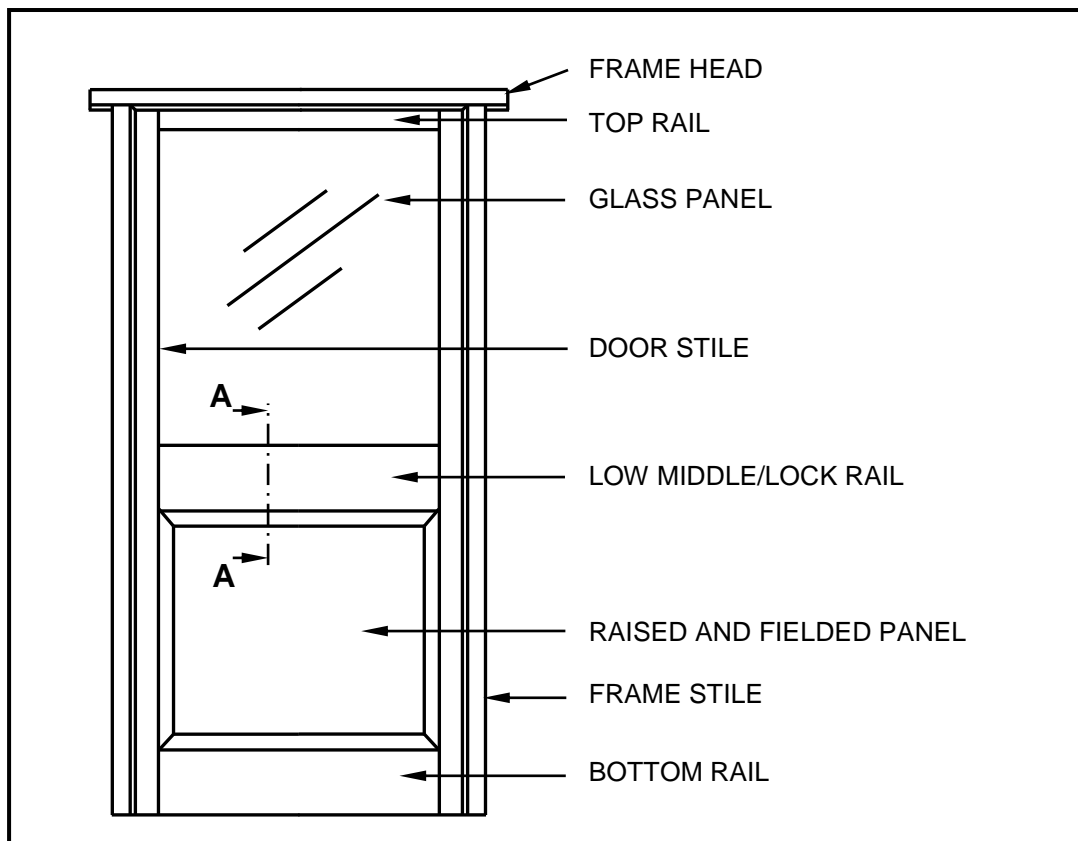

FIGURE 6.7

Use ANSWER SHEET 6.7 and draw, in good proportion, a vertical sectional view on A-A.

(9)  
[40]

TOTAL: 200



<b>CENTRE NUMBER:</b>									
-----------------------	--	--	--	--	--	--	--	--	--

<b>EXAMINATION NUMBER:</b>																			
----------------------------	--	--	--	--	--	--	--	--	--	--	--	--	--	--	--	--	--	--	--

**ANSWER SHEET 2**

<b>NO.</b>	<b>QUESTIONS</b>	<b>ANSWERS</b>	<b>MARKS</b>
1.	Identify the scale that was used for the site plan and the floor plan respectively.		2
2.	Who is responsible for checking the building plan?		1
3.	What type of fencing does the architect recommend for the new dwelling?		1
4.	Name the town where the new dwelling will be erected.		1
5.	What was done as revision 1?		1
6.	Identify number 1.		1
7.	Identify number 3 by giving the abbreviation.		1
8.	Identify number 4.		1
9.	Identify number 5.		1
10.	Identify number 9.		1
11.	Identify number 11.		1
12.	Identify number 12.		1
13.	Identify the number that indicates the boundary line.		1
14.	Describe the purpose of number 2.		1
15.	Deduce the plot number of the existing dwelling from FIGURE A.		1
16.	What is omitted in Maple Street with reference to number 6?		1



17.	What leisure feature is located on the site plan?		1
18.	Draw the north symbol to show that the driveway side is facing east.		3
19.	What is the purpose of the north symbol on a house plan?		1
20.	Which feature indicates that this is a double-storey building?		1
21.	Deduce THREE faults from bedroom 2.		3
22.	Draw the symbol for a wash tub.		2
23.	Draw the symbol for a bath.		2
24.	Draw the symbol for a water meter.		2
25.	Describe TWO reasons why the local municipality would not approve FIGURE A.		2
26.	Calculate the length of the house. Give your answer in m. Show ALL calculations.		6
		<b>TOTAL:</b>	<b>40</b>



SC/NSC

**CENTRE NUMBER:**

--	--	--	--	--	--	--	--

**EXAMINATION NUMBER:**

--	--	--	--	--	--	--	--	--	--	--	--	--	--	--	--	--	--	--	--

**ANSWER SHEET 3.4**

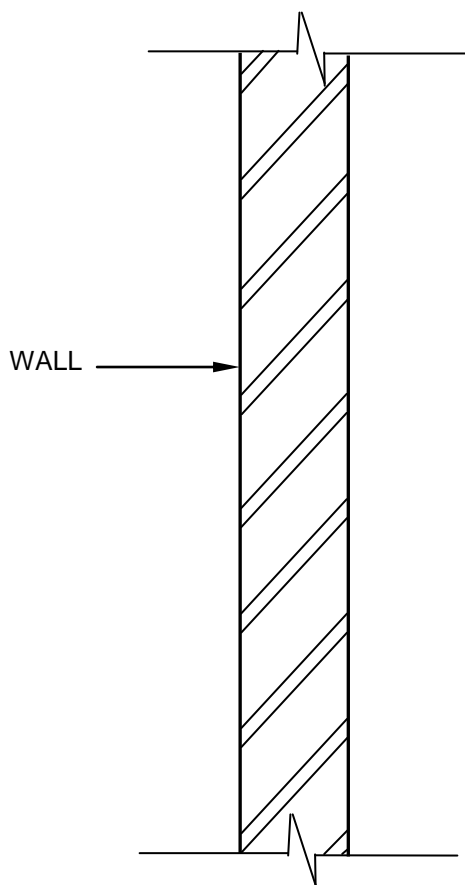

ASSESSMENT CRITERIA	MARK	CM
Correctness of drawing	4	
<b>TOTAL:</b>	<b>4</b>	



<b>CENTRE NUMBER:</b>									
-----------------------	--	--	--	--	--	--	--	--	--

<b>EXAMINATION NUMBER:</b>														
----------------------------	--	--	--	--	--	--	--	--	--	--	--	--	--	--

**ANSWER SHEET 3.5**

	<b>A</b>	<b>B</b>	<b>C</b>	<b>D</b>	
3.5.1					
3.5.2					(3)
3.5.3					(3)
					(4)



**CENTRE NUMBER:**

--	--	--	--	--	--	--	--

**EXAMINATION NUMBER:**

--	--	--	--	--	--	--	--	--	--	--	--	--	--	--	--	--	--	--	--

**ANSWER SHEET 4.5**

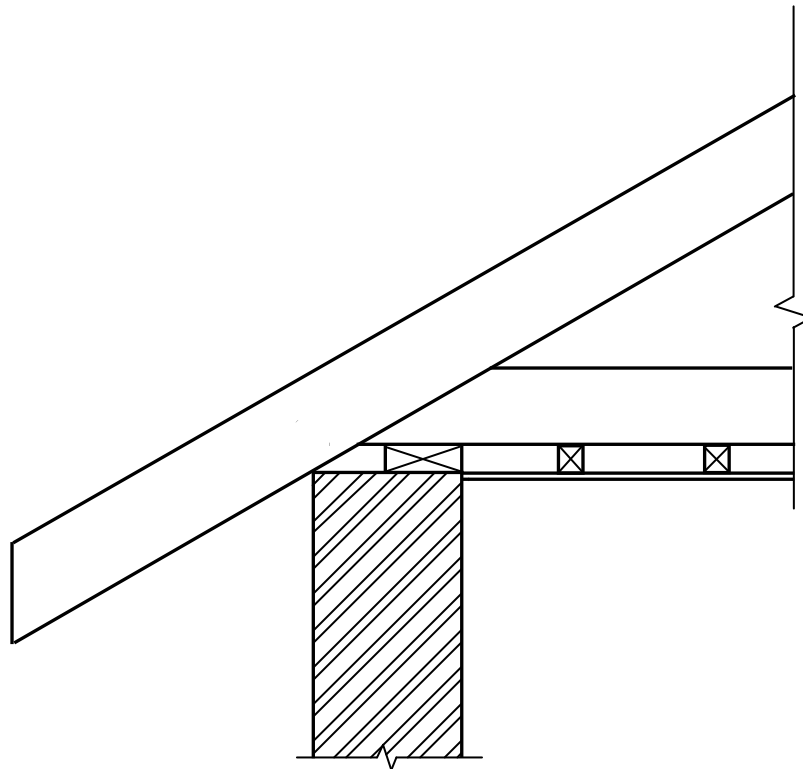

ASSESSMENT CRITERIA	MARK	CM
Correctness of drawing	10	
Any TWO labels with dimensions	4	
<b>TOTAL:</b>	<b>14</b>	



<b>CENTRE NUMBER:</b>									
-----------------------	--	--	--	--	--	--	--	--	--

<b>EXAMINATION NUMBER:</b>														
----------------------------	--	--	--	--	--	--	--	--	--	--	--	--	--	--

**ANSWER SHEET 4.6**

<b>ASSESSMENT CRITERIA</b>	<b>MARK</b>	<b>CM</b>
Correctness of drawing	8	
<b>TOTAL:</b>	<b>8</b>	



<b>CENTRE NUMBER:</b>									
-----------------------	--	--	--	--	--	--	--	--	--

<b>EXAMINATION NUMBER:</b>														
----------------------------	--	--	--	--	--	--	--	--	--	--	--	--	--	--

**ANSWER SHEET 5.3**

<b>ASSESSMENT CRITERIA</b>	<b>MARK</b>	<b>CM</b>
Correctness of drawing	4	
Any TWO labels with dimensions	4	
<b>TOTAL:</b>	<b>8</b>	





**CENTRE NUMBER:**

**EXAMINATION NUMBER:**

**ANSWER SHEET 5.4**

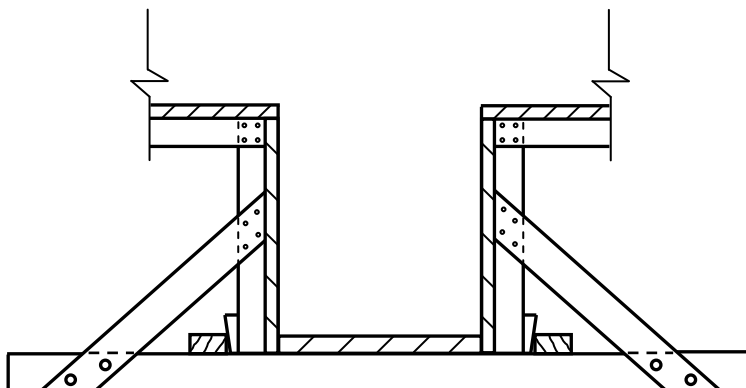

ASSESSMENT CRITERIA	MARK	CM
Correctness of drawing	9	
Any TWO labels	2	
<b>TOTAL:</b>	<b>11</b>	



<b>CENTRE NUMBER:</b>								
-----------------------	--	--	--	--	--	--	--	--

<b>EXAMINATION NUMBER:</b>														
----------------------------	--	--	--	--	--	--	--	--	--	--	--	--	--	--

**ANSWER SHEET 6.5**

<b>ASSESSMENT CRITERIA</b>	<b>MARK</b>	<b>CM</b>
Correctness of drawing	6	
<b>TOTAL:</b>	<b>6</b>	



**CENTRE NUMBER:**

**EXAMINATION NUMBER:**

**ANSWER SHEET 6.6**

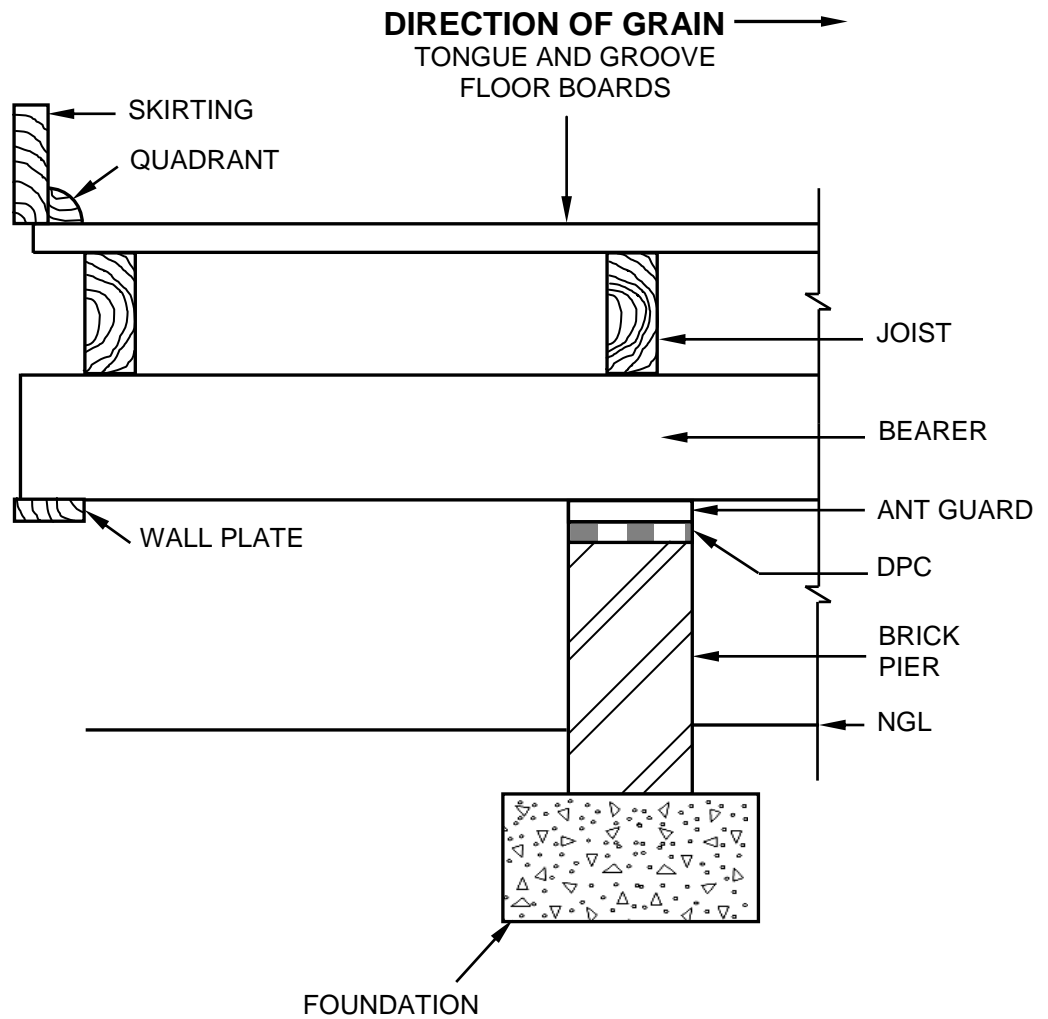

ASSESSMENT CRITERIA	MARK	CM
Correctness of drawing	8	
<b>TOTAL:</b>	<b>8</b>	



<b>CENTRE NUMBER:</b>									
-----------------------	--	--	--	--	--	--	--	--	--

<b>EXAMINATION NUMBER:</b>														
----------------------------	--	--	--	--	--	--	--	--	--	--	--	--	--	--

**ANSWER SHEET 6.7**

<b>ASSESSMENT CRITERIA</b>	<b>MARK</b>	<b>CM</b>
Correctness of drawing	9	
<b>TOTAL:</b>	<b>9</b>	

