



**NATIONAL  
SENIOR CERTIFICATE**

**GRADE 12**

**SEPTEMBER 2023**

**ELECTRICAL TECHNOLOGY: POWER SYSTEMS  
MARKING GUIDELINE**

**MARKS: 200**

---

This marking guideline consists of 14 pages.

---

**INSTRUCTIONS TO MARKERS**

1. All calculations with multiple answers imply that any relevant, acceptable answer should be considered.
2. Calculations:
  - 2.1 All calculations must show the formulae.
  - 2.2 Substitution of values must be done correctly.
  - 2.3 All answers **MUST** contain the correct unit to be considered.
  - 2.4 Alternative methods must be considered, provided that the correct answer is obtained.
  - 2.5 Where an incorrect answer could be carried over to the next step, the first answer will be deemed incorrect. However, should the incorrect answer be carried over correctly, the marker has to re-calculate the values, using the incorrect answer from the first calculation. If correctly used, the candidate should receive the full marks for subsequent calculations.
  - 2.6 Markers should consider that learners answers may deviate slightly from the marking guideline depending on how and where in the calculation rounding off was used.
3. These marking guidelines are only a guide with model answers.
4. Alternative interpretations must be considered and marked on merit. However, this principle should be applied consistently throughout the marking session at ALL marking centres.

**QUESTION 1: MULTIPLE-CHOICE QUESTIONS**

- 1.1 B ✓ (1)
- 1.2 A ✓ (1)
- 1.3 C ✓ (1)
- 1.4 C ✓ (1)
- 1.5 A ✓ (1)
- 1.6 B ✓ (1)
- 1.7 C ✓ (1)
- 1.8 D ✓ (1)
- 1.9 C ✓ (1)
- 1.10 B ✓ (1)
- 1.11 D ✓ (1)
- 1.12 A ✓ (1)
- 1.13 D ✓ (1)
- 1.14 B ✓ (1)
- 1.15 C ✓ (1)

**[15]**

**QUESTION 2: OCCUPATIONAL HEALTH AND SAFETY**

- 2.1
- Integrity ✓
  - Sense of responsibility ✓
  - Emphasis on quality
  - Discipline
  - Sense of teamwork
- (Any 2 x 1) (2)
- 2.2 An event that causes grave or severe physical injury to a person, ✓  
threatening their health and safety. ✓ (2)
- 2.3
- Avoid direct contact with any chemical ✓
  - Always wear personal protective clothing
  - Always read and be aware of the warning symbols on containers
- (Any 1 x 1) (1)
- 2.4 An unsafe act is the wilful performance of a task or activity in a manner that  
may threaten the health and safety of everyone. ✓  
A calculated risk is the probability that injury or damage may occur while  
using dangerous equipment. ✓ (2)
- 2.5
- To prevent oneself from being electrocuted. ✓
  - To prevent injury
- (Any 1 x 1) (1)
- 2.6 This could damage the equipment and render the equipment unsafe ✓ and  
compromise the safety of the user. ✓ (2)
- [10]**

**QUESTION 3: RLC CIRCUITS**

3.1 It is the opposition offered to current flow by the reactive components of an inductor, ✓ when it is connected to an AC supply. ✓ (2)

3.2

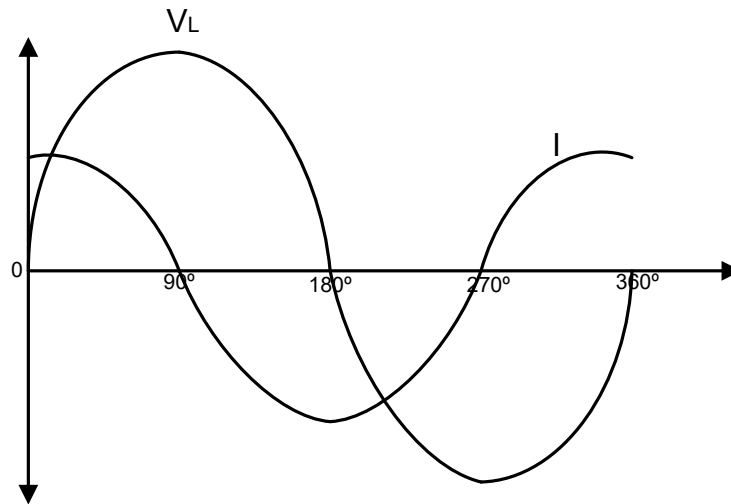

- Full cycles drawn correctly ✓
  - Phase difference correct ✓
  - Waveforms labelled correctly ✓
- (3)

3.3 3.3.1  $X_C = \frac{1}{2\pi f C}$  ✓  
 $= \frac{1}{2 \times \pi \times 60 \times 200 \times 10^{-6}}$  ✓  
 $= 13,26 \Omega$  ✓

(3)

3.3.2  $I = \frac{V}{Z}$  ✓  
 $= \frac{110}{101,65}$  ✓  
 $= 1,08 \text{ A}$  ✓

(3)

3.3.3  $Z = \sqrt{R^2 + (X_L - X_C)^2}$  ✓  
 $R = \sqrt{Z^2 - (X_L - X_C)^2}$   
 $= \sqrt{101,65^2 - (31,55 - 13,26)^2}$  ✓  
 $= 100 \Omega$  ✓

(3)

3.3.4  $X_L = 2\pi f L$  ✓  
 $L = \frac{X_L}{2\pi f}$   
 $= \frac{31,55}{2 \times \pi \times 60}$  ✓  
 $= 0,084 \text{ H} = 84 \text{ mH}$  ✓

(3)

$$\begin{aligned}
 3.4 \quad f_r &= \frac{1}{2\pi\sqrt{LC}} \checkmark \\
 &= \frac{1}{2 \times \pi \times \sqrt{50 \times 10^{-3} \times 60 \times 10^{-6}}} \checkmark \\
 &= 91,89 \text{ Hz} \checkmark
 \end{aligned} \tag{3}$$

$$\begin{aligned}
 3.5 \quad 3.5.1 \quad I_C &= \frac{V}{X_C} \checkmark \\
 &= \frac{100}{11,83} \checkmark \\
 &= 8,45 \text{ A} \checkmark
 \end{aligned} \tag{3}$$

$$\begin{aligned}
 3.5.2 \quad I_T &= \sqrt{I_R^2 + (I_C - I_L)^2} \checkmark \\
 &= \sqrt{9,09^2 + (8,45 - 4,54)^2} \checkmark \\
 &= 9,9 \text{ A} \checkmark
 \end{aligned} \tag{3}$$

$$\begin{aligned}
 3.5.3 \quad \cos\theta &= \frac{I_R}{I_T} \checkmark \\
 &= \frac{9,09}{9,9} \checkmark \\
 &= 0,918 \checkmark
 \end{aligned} \tag{3}$$

3.5.4 Leading,  $\checkmark$  because  $I_C$  is larger than  $I_L$ .  $\checkmark$  (2)

3.6 Selectivity is a measure of how well a resonant circuit responds to a range of frequencies  $\checkmark$  and separates other frequencies.  $\checkmark$  (2)

- 3.7
- The value of the series resistor  $\checkmark$
  - The LC ratio  $\checkmark$

(2)  
**[35]**

**QUESTION 4: THREE-PHASE AC GENERATION**

4.1 4.1.1 B ✓ (1)

4.1.2 C ✓ (1)

4.1.3 A ✓ (1)

4.2

- Installation costs are high ✓
- Not available everywhere ✓
- Not suitable for most residential applications
- Appliances are expensive

(Any 2 x 1) (2)

4.3

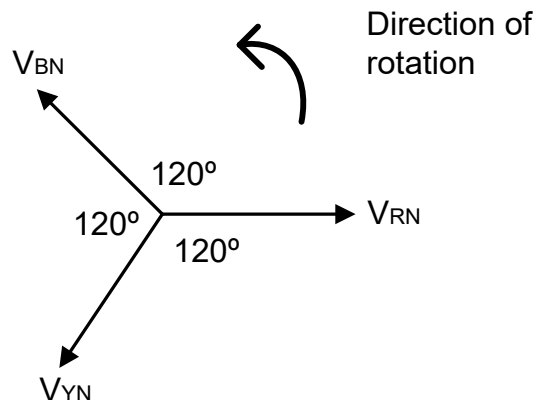

- 120° ✓
- Direction of rotation ✓
- Phasors drawn correctly ✓
- Labelling of phasors ✓

(4)

4.4

- Static capacitors ✓
- Synchronous motors ✓
- Phase advances ✓

(3)

4.5 4.5.1  $V_L = V_{PH} ✓$   
 $= 415 V ✓$  (2)

4.5.2  $I_{PH} = \frac{V_{PH}}{R_{PH}} ✓$   
 $= \frac{415}{45} ✓$   
 $= 9,22 A ✓$   
 $I_L = \sqrt{3} I_{PH} ✓$   
 $= \sqrt{3} \times 415 ✓$   
 $= 15,97 A ✓$  (6)

4.5.3  $P = \sqrt{3} V_L I_L \cos\theta ✓$   
 $= \sqrt{3} \times 415 \times 15,97 \times 0,86 ✓$   
 $= 9\ 872,16 W = 9,87 kW ✓$  (3)

$$\begin{aligned} 4.5.4 \quad \eta &= \frac{P_{\text{output}}}{P_{\text{input}}} \times 100\% \\ &= \frac{9\,872,16}{12\,000} \times 100 \checkmark \\ &= 82,27\% \checkmark \end{aligned} \quad (3)$$

$$\begin{aligned} 4.5.5 \quad \cos \theta &= 0,86 \checkmark \\ \theta &= \cos^{-1}(0,86) \checkmark \\ &= 30,68^\circ \checkmark \end{aligned} \quad (3)$$

$$\begin{aligned} 4.6 \quad P_{\text{TOT}} &= W_1 + W_2 + W_3 \checkmark \\ &= 2\,000 + 1\,780 + 3\,500 \checkmark \\ &= 7\,280 \text{ W} = 7,28 \text{ kW} \checkmark \end{aligned} \quad (3)$$

- 4.7
- Connect the current coils to two of the phases. ✓
  - Connect the positive terminals of the voltage coils to the same two phases. ✓
  - Connect both of the negative terminals to the third phase. ✓
- (3)

**[35]**



**QUESTION 5: THREE-PHASE TRANSFORMERS**

- 5.1
- Eddy current losses ✓
  - Hysteresis losses ✓
- (2 x 1) (2)
- 5.2 The excessive temperatures may cause serious problems ✓ like insulation failure. ✓ (2)
- 5.3
- 5.3.1 False ✓ (1)
- 5.3.2 True ✓ (1)
- 5.3.3 True ✓ (1)
- 5.4
- Cools the windings ✓
  - Improves the insulation
- (Any 1 x 1) (1)
- 5.5
- 5.5.1 Heavy industries, where a high-power transfer is essential. ✓  
Large low voltage systems that carry large currents. (Any 1 x 1) (1)
- 5.5.2  $V_{LP} = V_{PP}$  ✓  
 $= 11 \text{ kV}$  ✓  
 $V_{LS} = V_{PP}$  ✓  
 $= 380 \text{ V}$  ✓ (4)
- 5.5.3  $P = \sqrt{3}V_{LS}I_{LS}\cos\theta$  ✓  
 $I_{LS} = \frac{P}{\sqrt{3}V_{LS}\cos\theta}$   
 $= \frac{20\,000}{\sqrt{3} \times 380 \times 0,88}$  ✓  
 $= 34,53 \text{ A}$  ✓ (3)
- 5.5.4  $I_{PS} = \frac{I_{LS}}{\sqrt{3}}$  ✓  
 $= \frac{34,53}{\sqrt{3}}$  ✓  
 $= 19,94 \text{ A}$  ✓ (3)
- 5.5.5  $P = S \cos \theta$  ✓  
 $S = \frac{P}{\cos \theta}$   
 $= \frac{20\,000}{0,88}$  ✓  
 $= 22\,727,27 \text{ VA} = 22\,73 \text{ kVA}$  ✓ (3)

$$\begin{aligned} 5.5.6 \quad \text{Transformer ratio} &= V_{PP} : V_{PS} \checkmark \\ &= 11\,000 : 380 \checkmark \\ &= 28,95 : 1 \checkmark \end{aligned} \quad (3)$$

$$\begin{aligned} 5.5.7 \quad \eta &= \frac{P_{LOAD}}{P_{LOAD} + losses} \times 100\% \checkmark \\ Losses &= \frac{P_{LOAD} \times 100}{88} - P_{LOAD} \\ &= \frac{20\,000 \times 100}{88} - 20\,000 \checkmark \\ &= 2\,727,27 \text{ W} = 2,73 \text{ kW} \checkmark \end{aligned} \quad (3)$$

5.6 This will decrease the secondary current,  $\checkmark$  resulting in a decrease in the primary current due to the decrease of the magnetic force.  $\checkmark$  (2)

**[30]**

**QUESTION 6: THREE-PHASE MOTORS AND STARTERS**

6.1 The rotor consists of copper or aluminium conducting rods, ✓ mounted slightly skew, ✓ and connected to the two end rings. ✓ (3)

6.2 The slope of the torque is approximately proportional to the slip. ✓ (1)

6.3 6.3.1  $N_s = \frac{60 \cdot f}{p}$  ✓  
 $f = \frac{N_s \cdot p}{60}$   
 $= \frac{3\,600 \times 2}{60}$  ✓  
 $= 120 \text{ Hz}$  ✓ (3)

6.3.2  $\% \text{ slip} = \frac{N_s - N_r}{N_s} \times 100$  ✓  
 $= \frac{3\,600 - 3\,400}{3\,600} \times 100$  ✓  
 $= 5,56\%$  ✓ (3)

6.4 6.4.1  $P_{INPUT} = \sqrt{3} V_L I_L \cos \theta$  ✓  
 $V_L = \frac{P}{\sqrt{3} I_L \cos \theta}$   
 $= \frac{10\,000}{\sqrt{3} \times 18,99 \times 0,8}$  ✓  
 $= 380,04 \text{ V}$  ✓ (3)

6.4.2  $P_{OUTPUT} = \sqrt{3} V_L I_L \cos \theta \eta$  ✓  
 $= \sqrt{3} \times 380,04 \times 18,99 \times 0,8 \times \frac{90}{100}$  ✓  
 $= 9\,000,1 \text{ W} = 9 \text{ kW}$  ✓ (3)

6.4.3  $Q = \sqrt{3} V_L I_L \sin \theta$  ✓  
 $= \sqrt{3} \times 380,04 \times 18,99 \times \sin 36,87$  ✓  
 $= 7\,500,1 \text{ VA}_r = 7,5 \text{ VA}_r$  ✓ (3)

- 6.5
- Insulation resistance test ✓
  - Continuity test ✓
  - Check for loose connections
  - Bearing test
- (Any 2 x 1) (2)

6.6 A normally closed contact of the forward contactor is connected in series with the coil of the reverse contactor ✓ and a normally closed contact of the reverse contactor is connected in series with the coil of the forward contactor. ✓ (2)

- 6.7 6.7.1 Automatic star delta ✓ (1)
- 6.7.2 A – stop button ✓  
B – start button ✓  
C –  $\frac{MC_1N}{O_1}$  ✓ (3)
- 6.7.3 The N/C timer keeps the star contactor energized, until the preset time is reached then it opens. ✓ After the preset time the N/O contact closes and the delta contactor is energised. ✓ (2)
- 6.7.4 Overload setting =  $125\% \times \text{rated current}$  ✓  
=  $1,25 \times 8$  ✓  
= 10 A ✓ (3)
- 6.7.5 The motor would still run, in star for the preset time. ✓ After the preset time the current will flow to the delta coil but it will not energise, ✓ and the motor will stop. ✓ (3)

**[35]**

**QUESTION 7: PROGRAMMABLE LOGIC CONTROLLERS**

7.1 A PLC is an industrial computer, ✓ that is programmed to perform a number of routine tasks, ✓ in a strict order at exactly the right time. ✓ (3)

7.2 Modems are circuits the PLC uses to connect its CPU to the input sensing devices ✓ as well as the output load devices. ✓ (2)

7.3 7.3.1 NOR gate ✓ (1)

7.3.2

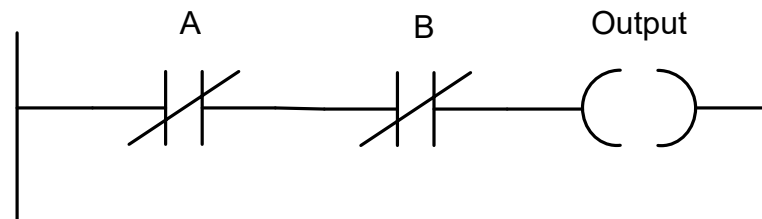

1 mark for each correctly labelled symbol.

Symbols only = 1 mark only

(3)

7.3.3 a – 1 ✓

b – 0 ✓

c – 0 ✓

d – 0 ✓

(4)

7.4

- Measure tank levels ✓
- High/low level alarms ✓
- Irrigation control
- Monitoring of rivers and dams
- Remote monitoring of chemical, petrol, and diesel manufacturing

(Any 2 x 1) (2)

7.5

- AC induction motors speed depends on the frequency of the supply. ✓
- A variable speed control receives the frequency, and its circuitry increases or decreases the output frequency to the motor. ✓
- This varying of the frequency then increases or decreases the motor speed. ✓

(3)

7.6 7.6.1 Diode bridge rectifier converts an AC voltage ✓ to a DC voltage. ✓ (2)

7.6.2 Filter smooths the AC ripple ✓ to ensure a pure DC voltage on the DC rail. ✓ (2)

7.6.3 The inverter inverts the DC voltage ✓ back to an AC voltage, at a variable frequency, ✓ that controls the motor speed. ✓ (3)

7.7 7.7.1 Lamp 1 comes on once the motor is energised ✓ to indicate that it is running. ✓ (2)

7.7.2 The overload protects the motor, ✓ by switching the supply off to the motor when excessive currents flow. ✓ (2)

7.7.3 If lamp 2 was fused, there would no indication ✓ that the motor was not energised. ✓ (2)

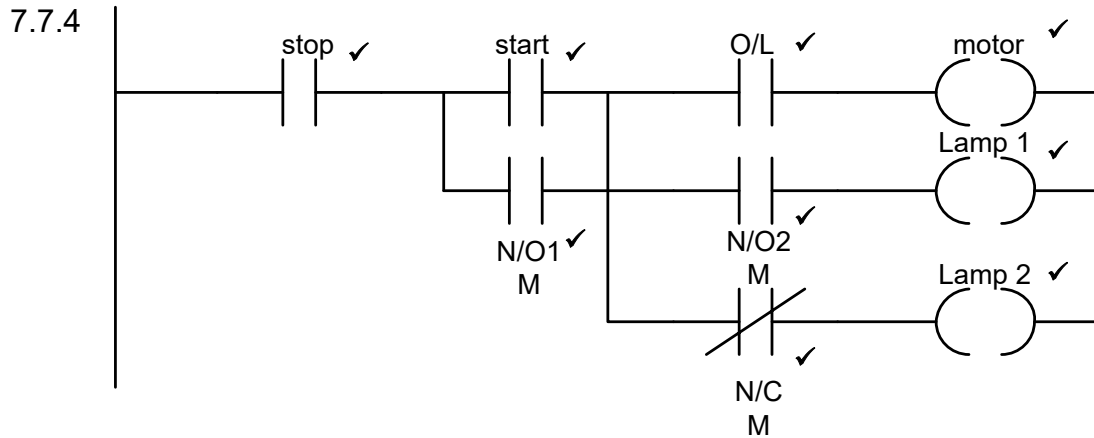

(9)  
[40]

**TOTAL: 200**